CS20-Product datasheet

Revision of previous versions			
Date	Version	Description	Author
2022/09/06	V1.0		Terry/Daisy
2022/12/20	V1.1	The single frequency parameter of CS20 is added	Terry
2023/02/03	V1.2	Modify the description of the dual-frequency parameter	Terry
2023/12/06	V1.3	Modify the dimension description	Terry

Catalog

1. Description and characteristics	1
2. Introduction	2
2.1 Purpose of this document	2
2.2 Overview of ToF (Time of Flight) technology	2
2.3 Block diagram of a solid-state LiDAR system	4
2.4 Technical parameters	5
3. Component specifications	6
3.1 ToF modules	6
3.1.1 ToF module image sensor	6
3.1.2 ToF module laser emitter	6
3.2 ISP motherboard	7
3.3 power consumption	8
4. Performance evaluation	9
5. Mechanical structure	10
6. Storage conditions	11
7. Camera Cleaning Steps	11
8. Software	11
9. Regulatory Compliance	12
Disclaimer	13

1. Description and characteristics

Product Description:

CS20 is a solid-state LiDAR, equipped with a ToF image sensor with a resolution of 640*480, which uses ToF technology to obtain three-dimensional information of objects and space, with excellent performance such as long distance and low power consumption, providing users with convenient and efficient 3D perception capabilities.

The product is powered through the Type C interface and outputs depth image phase information at the same time, and users can obtain depth, IR, point cloud and other data through the SDK.

Features

- Centimeter-level measurement accuracy
- Measuring range: 0.1-3.75m @90% Ref
- High dynamic measuring range
- Support depth and signal amplitude timing synchronization
- Adjustable capacity and resolution

Applicable scenarios

- Robot obstacle avoidance
- Industrial vision
- Volumetric measurements
- Liveness detection
- Somatosensory interaction
- 3D modeling

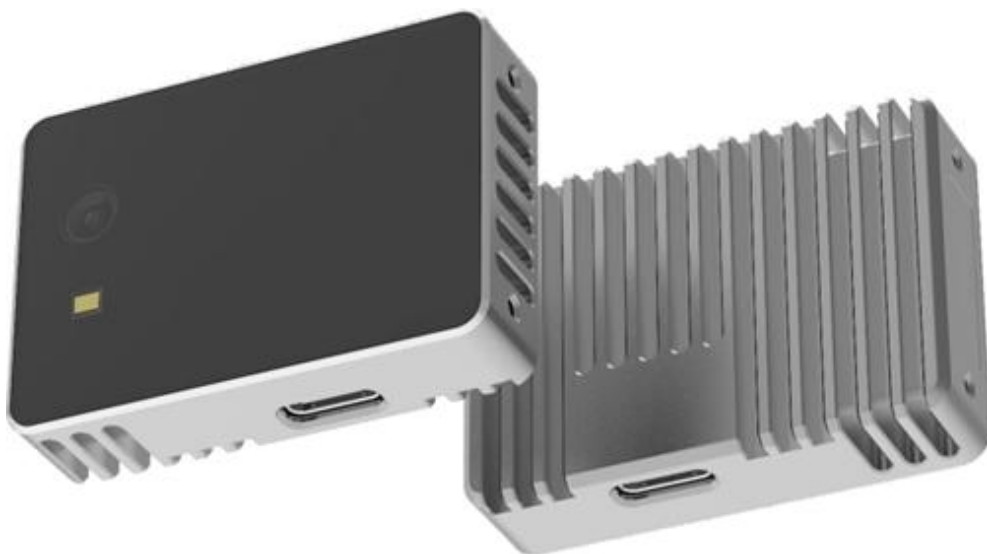

Figure 1-1. Exterior view of the CS20 solid-state LiDAR

2. Introduction

2.1 Purpose of this document

This document details the specifications of the CS20 solid-state LiDAR and provides users with the relevant information they need to understand and use the CS20 solid-state LiDAR.

2.2 Overview of ToF (Time of Flight) technology

ToF technology calculates the distance between an object and the camera by the time of flight of light. First, the ToF sensor gives the modulation signal to the light source driver chip, and then the modulation signal emits high-frequency modulated near-infrared light by controlling the laser, and when the light encounters the measured object, it is diffusely reflected back to the sensor receiver, and the depth information is calculated by the time difference between the emitted and received light.

The CS20 solid-state LiDAR uses continuous wave modulation (CW-iToF) in i-ToF (indirect ToF). Through the proportional relationship of the energy value collected by the sensor in different time windows, the signal phase is analyzed, and the time difference between the transmitted signal and the received signal is indirectly measured, and then the depth is obtained.

Continuous Wave Modulation (K-Itov)

Sine wave modulation is usually used, and the phase offset of the sine wave at the receiving and transmitting ends is proportional to the distance of the object from the camera, and the distance is measured by the phase offset

$$\varphi_{TOF} = \text{atan} \left(\frac{C_1 - C_3}{C_2 - C_4} \right)$$
$$D = \frac{c}{2} * \frac{\varphi_{TOF}}{2\pi * f_m} + D_{offset}$$

Formula 2-1. Distance calculation

The phase offset (φ) and depth (D) are obtained from the integrated energy values parsed from the above equations C1, C2, C3, and C4, which are the energies collected by the receiving windows of four different phase delays, corresponding to the samples at the phase sampling points at 0° , 90° , 180° , and 270° , respectively, namely:

$$\begin{aligned}C_1 &= A\sin(\varphi) \\C_2 &= A\sin(\varphi + 90^\circ) = A\cos(\varphi) \\C_3 &= A\sin(\varphi + 180^\circ) = -A\sin(\varphi) \\C_4 &= A\sin(\varphi + 270^\circ) = -A\cos(\varphi)\end{aligned}$$

Formula 2-2. Energy value and phase

where A is the amplitude of the received sinusoidal signal.

In terms of accuracy, the accuracy of CW-iToF is mainly constrained by random noise, which is inversely proportional to the signal-to-noise ratio (SNR) of the received optical signal, and quantization noise, which is inversely proportional to the frequency of sine wave modulation. Therefore, in order to improve the accuracy, CW-iToF generally uses high-power short-integration time sampling to improve the SNR of the received optical signal, and at the same time increases the modulation frequency to suppress the quantization noise.

In terms of range, CW-iToF can resolve the phase range of $[0\sim 2\pi]$, so its maximum range is $D_{\max}=c/(2fm)$. That is, the higher the frequency, the higher the accuracy and the smaller the measuring range. If the depth of the range is exceeded, a periodic phase wrap will occur, and the measured value will fall incorrectly within $[0\sim D_{\max}]$.

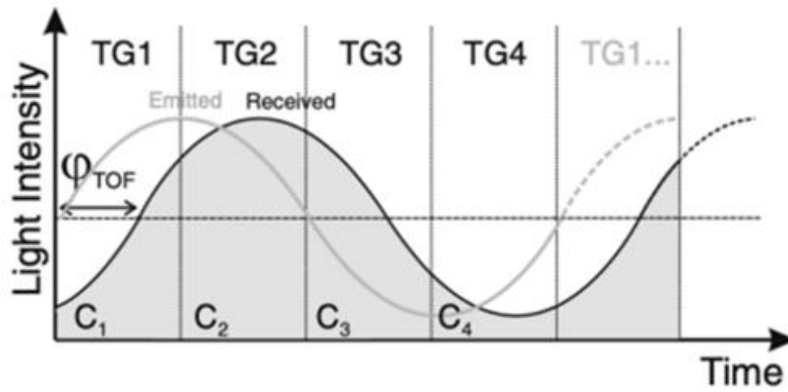

Figure 2-1. Light flight time vs. light intensity

2.3 Block diagram of a solid-state LiDAR system

The CS20 solid-state LiDAR hardware system consists of two main components, the ISP processor and the Depth module. The ISP processor is located on the motherboard, and the ToF module is fastened to the motherboard through connectors.

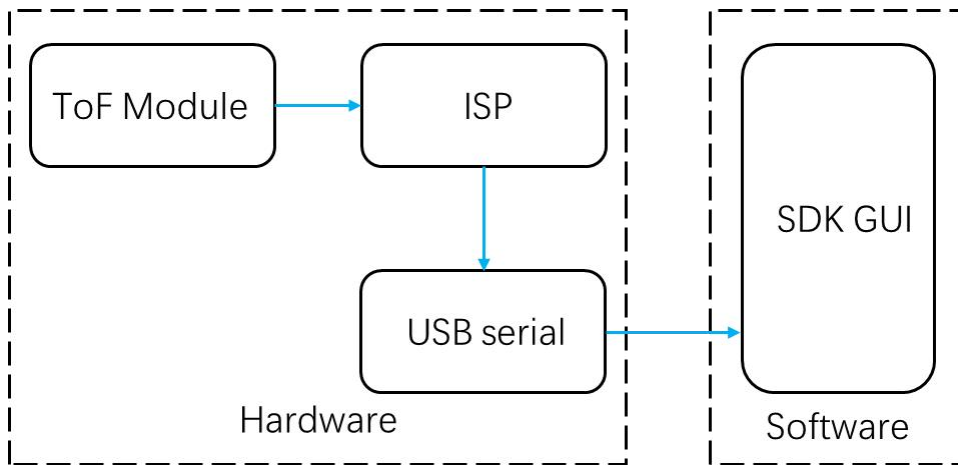

Figure 2-2. Block diagram of the CS20 solid-state LiDAR system

2.4 Technical parameters

Technical parameters		
Depth image	Resolution*1	640*480@8fps/320*240@20fps
	Resolution*2	320*240@25fps
	FOV	H60°xV45°
Basic parameters	Working distance*1	0.1-5m, indoor
	Working distance*2	0.1-3.75m, indoor
	Accuracy*1	0.1~0.5m@±2.5cm; 0.5~5m@±1%
	Accuracy*2	0.1~0.5m@±2.5cm; 0.5~3.75m@±1.5%
	VCSEL wavelength	940nm
	Product dimensions	48mm x 34mm x 12mm
	Data transmission	USB 2.0 protocol , Type C Interface
	Power supply mode	5V, average 0.5A
	power consumption	average 1.2W
	operating system	Win 10, Linux, ROS
	Operating temperature	-10 ~ 50°C
	security	Laser CLASS1

Note: a.*1 and *2 are single and dual-frequency difference parameters, where *1 is the CS20 dual-frequency parameter, which is suitable for static scenarios. *2 is a CS20 single-frequency parameter, which is suitable for dynamic scenes.

b. Absolute accuracy test conditions: shoot 90% Ref chart at different distances, take 10*10 pixels in the center, and repeat 15 times to take the average value.

3. Component specifications

3.1 ToF modules

The ToF module components are as follows:

compose	description
ToF imager	Time of light image sensor
ToF emitter	Class 1 laser compliant (optional)
Other Components	Laser Driver, EEPROM, Voltage Regulators, FPC, Connector etc.

Table 3-1. ToF module components

3.1.1 ToF module image sensor

compose	description
Active Pixels	320*240
Sensor Aspect Ration	4: 3
Format	10-bit RAW
Shutter Type	Global shutter
Signal Interface	MIPI CSI-2, 2X Lanes
F Number	1.4
Effect Focal Length	3.90mm
Focus	Fixed
Horizontal Field of View	59.2
Vertical Field of View	46.0
Diagonal Field of View	71.0
TV Distortion (Trad.*2)	<1.5%

Table 3-2. ToF module image sensor parameters

3.1.2 ToF module laser emitter

The ToF laser emitter emits uniform near-infrared (940nm) light to the object, and the laser emitter meets the safety requirements of Class 1 lasers under normal operating conditions.

Items	Test Condition	Min	Typical	Max	Unit
Optical Output power	Pulse=3.5A, 50°C	2.3	2.7	-	W
Threshold current	Pulse 50°C	0.3	0.45	0.7	A
Operating Current	Pulse 50°C	-	3.5	-	A
Operating voltage	Pulse=3.5A, 50°C	-	2.14	2.6	V
Slope efficient	Pulse=3.5A, 50°C	0.8	1	-	mW/mA
Power conversion efficiency	Pulse=3.5A, 50°C	33	36	-	%
Angle	Pulse=3.5A, 50°C	-	72	-	°
	Pulse=3.5A, 50°C	-	58	-	
Wavelength	If=6A, 50°C	930	940	950	nm
Wavelength coefficient	Pulse=3.5A	-	0.07	-	nm/°C

Table 3-3. Parameters of the laser emitter of the ToF module

3.2 ISP motherboard

Components	Description
ISP Processor	PC Camera Controller
8 MB Flash	PC Camera Controller firmware storage and ToF firmware storage
24 MHz Crystal	Clock source for Vision Processor
Depth Module Receptacle	(36+10)pin receptacle for connection to Depth Module
USB Type-C	USB peripheral connector for connection to Host USB 2.0 port
Voltage Regulators	DC to DC and LDO converters powering Vision Processor Board and depth module
Mounting holes	Vision Processor Board secure mounting

Table 3-5.ISP motherboard components

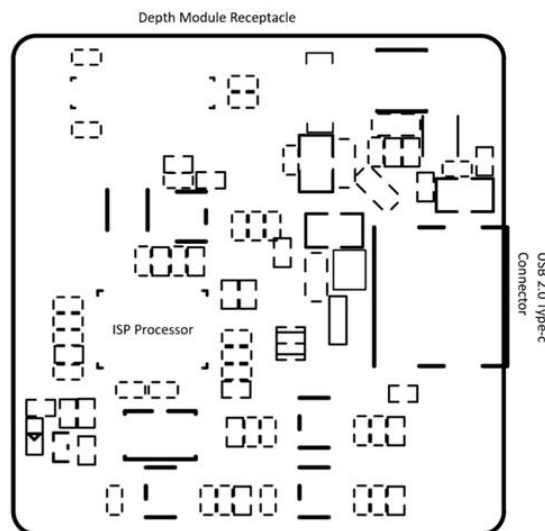

Figure 3-1. Schematic diagram of the CS20 ISP motherboard

Dimension	Min	Nominal	Max	Unit
Width	30.3	30.5	30.7	mm
Height	30.08	31.0	31.2	mm
Depth	4.85	4.90	4.95	mm
Weight	4.45	4.50	4.55	g

Table 3-6. ISP 主板尺寸

3.2.1 Type C description

A1	A4	A5	A6	A7	A8	A9	A12
GND	VBUS	CC1	DP1	DN1	SBU1	VBUS	GND
GND	VBUS	SBU2	DN2	DP2	CC2	VBUS	GND
B12	B9	B8	B7	B6	B5	B4	B1

Figure 3-2. USB Type-C Receptacle Pin Map

Pin	Signal	Function	Pin	Signal	Function
A1	GND	接地	B12	GND	接地
A4	VBUS	总线电源	B9	VBUS	总线电源
A5	CC1	Configuration channel	B8	SBU2	NC
A6	DP1	USB 2.0差分信号, position 1, 正	B7	DN2	USB 2.0差分信号, position 2, 负
A7	DN1	USB 2.0差分信号, position 1, 负	B6	DP2	USB 2.0差分信号, position 2, 正
A8	SBU1	NC	B5	CC2	Configuration channel
A9	VBUS	总线电源	B4	VBUS	总线电源
A12	GND	接地	B1	GND	接地

Figure 3-3. USB Peripheral Connector Pin List

3.3 power consumption

state	Imin (mA)	Iavg (mA)	Ipp (mA)
Standby(Whole machine)	91	195	1896
Standby	5	5	5

Supply voltage: VBUS=5V, the measured data is based on exposure time=580us.

Table 3-7. CS20 solid-state LiDAR power consumption metrics

4. Performance evaluation

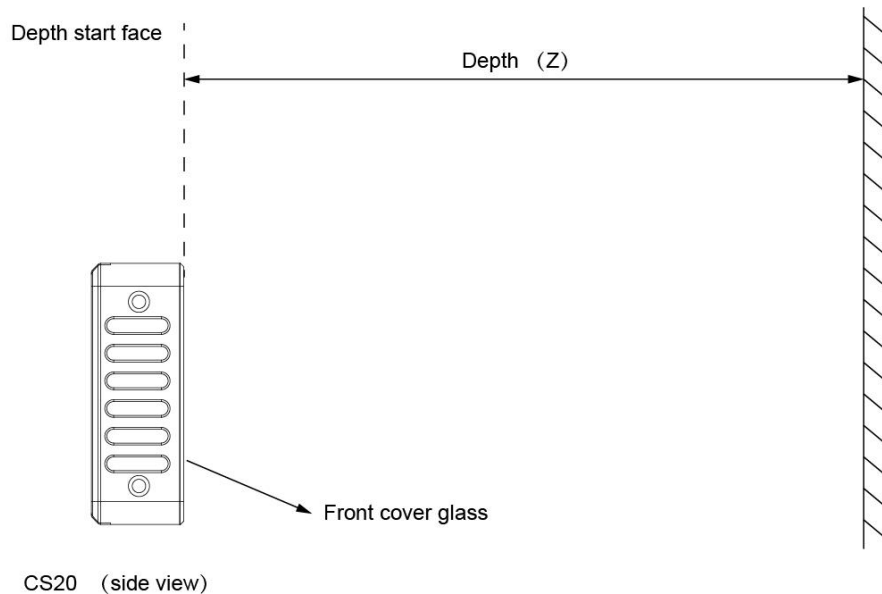

Figure 4-1 CS20 Review Starting Point

- 1) Absolute accuracy: refers to the difference between the measurement result and the true value, which is used to characterize the proximity of the measurement result to the true value, and its formula is defined as follows:

$$Accuracy = \left| \frac{\sum_i depth_i}{N} - D \right|$$

- 2) Inter-frame noise: It is used to evaluate the stability of depth data between multiple frames, and the formula of inter-frame noise is defined as follows:

$$Temporal\ noise = \frac{1}{N} \sum_i \sqrt{\frac{\sum_j \left(depth_j - \frac{\sum_j depth_j}{M} \right)^2}{M}}$$

- 3) Point cloud thickness: Take pictures of the white wall and test the point cloud thickness of the white wall at different distances

5. Mechanical structure

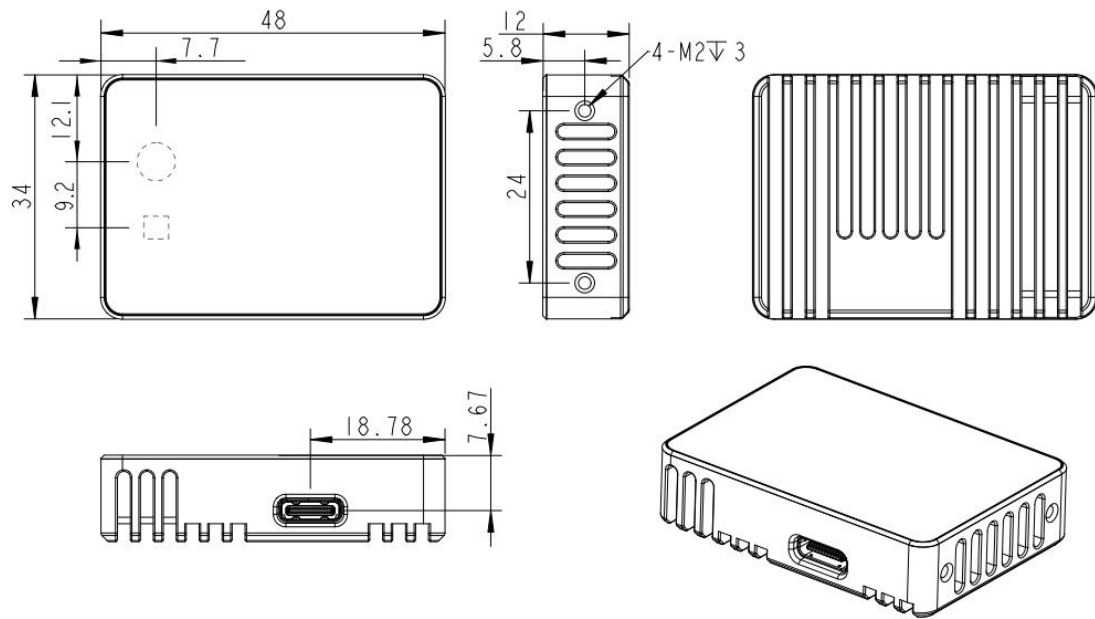

Figure 5-1 Schematic diagram of the CS20 solid-state LiDAR structure

Dimension	Min	Nominal	Max	Unit
Width	47.74	47.94	48.14	mm
Height	33.8	34	34.2	mm
Depth	11.8	12	12.2	mm
Weight	32.5	33	33.5	g

Table 5-1. Structural dimensions

6. Storage conditions

Condition	Description	Min	Max	Unit
Storage Temperature		-15	60	°C
	Humidity	Temperature/RH: 40°C/90%		
Work Temperature		-10	50	°C

7. Camera Cleaning Steps

1. Do not use any chemicals or water on the camera lens.
2. Use the lens purge brush to remove as much dust and dirt as possible from the lens.
3. Wipe with a dry, clean microfiber cloth.

8. Software

- [Windows client---Credimension Viewer](#)

Credimension Viewer CS20 series of windows demo GUI tools. This tool is mainly used to obtain, display, and save Depth, IR, and Point cloud information, and also supports functions such as viewing basic device information, setting resolution, integration time, etc.

- [SDK---CSAPI](#)

Customers can use the CS20 SDK for secondary development, which supports Windows/Linux (Ubuntu/ARMv7/ARMv8)/ROS platforms, and has specific performance optimizations for the embedded architecture.

9. Regulatory Compliance

“ ROHS, CE, FCC, CLASS 1 ”

Disclaimer

Device application information and other similar content described in this publication is provided for your convenience only and may be superseded by updated information. It is your responsibility to ensure that your application complies with the technical specifications. The Company makes no representations or warranties of any kind, express or implied, written or oral, statutory or otherwise, with respect to such information, including, but not limited to, representations or warranties of use, quality, performance, merchantability or fitness for a particular purpose. The Company shall not be liable for any such information or the consequences arising from the use of such information. This product may not be used as a critical component in a life support system without the written approval of the Company.