

---

## CS30 Product Manual

---

Revision Update Date			
Date	Revision	Description	Editor
December 3, 2021	V1.0		Evan
July 1, 2022	V1.1	Update technical parameters	Daisy
July 1, 2022	V1.2	Update schema diagram	Terry
September 6, 2022	V1.3	1. Corrected module laser emitter parameters 2. Update structural drawings	Terry
December 6, 2023	V1.4	Modify size description	Terry
April 18, 2024	V1.5	Added the relationship between frame rate and resolution	Terry



# Table of contents

1. Description and Features .....	1
2. Introduction .....	2
2.1 Purpose of this document .....	2
2.2 ToF Technology overview .....	2
2.3 Camera System Frame Diagram.....	3
2.4 Technical parameter .....	4
3. Component Specifications.....	5
3.1 ToF module .....	5
3.1.1 ToF Module Image Sensor.....	5
3.1.2 ToF Module Laser Emitter.....	5
3.2 RGB Module .....	6
3.3 Processor Mainboard.....	7
3.4 Power consumption .....	8
4. Performance evaluation .....	9
5. Mechanical structure .....	11
6. Storage conditions .....	12
7. Camera Cleaning Steps.....	12
8. Software.....	12
9. Compliance regulations .....	13
Disclaimer .....	13

# 1. Description and Features

## Product Description

CS30 is an RGBD depth camera, equipped with 640\*480 resolution ToF image sensor and 1920\*1080 resolution color image sensor. It uses ToF technology to obtain three-dimensional information of objects and spaces. It has long distance and low power consumption, as well as other excellent performance, providing users with convenient and efficient 3D perception capabilities.

CS30 is powered through the Type C interface. And output depth image and 2D color image information at the same time, support 3D point cloud and 2D color image fusion.

### Features

- Millimeter measurement accuracy
- measuring range: 0.1-5m@90% Ref
- Support RGBD fusion
- Supports switching depth/color image resolution

### Applicable scene

- Robot SLAM
- Industrial Vision
- Volume measurement
- Liveness detection
- somatosensory interaction
- 3D modeling



Figure 1-1. CS30 RGBD Appearance of the depth camera

## 2. Introduction

### 2.1 Purpose of this document

This document introduced the detail specifications and parameters of the RGBD depth camera CS30. And Providing users with the relevant information to understand and use the CS30 RGBD depth camera.

### 2.2 ToF Technology overview

ToF technology calculates the distance between an object and the camera through the time-of-flight of light. Firstly, the ToF sensor sends a modulation signal to the light source driving chip, and then the modulation signal sends out high-frequency modulated near-infrared light by controlling the laser. When the light encounters the object to be measured and diffuse reflection back to the receiving end of the sensor, through the time difference between emitted and received light to calculate depth information.

CS30 RGBD depth camera adopts continuous wave modulation technology (CW-iToF) in i-ToF (indirect ToF). Through the ratio of the energy values collected by the sensor in different time windows, analyze the signal phase, indirectly measure the time difference between the transmitted signal and the received signal, and then obtain the depth.

#### **Continuous wave modulation (CW-iToF)**

Usually sine wave modulation is used, phase offset of sine waves at receiver and emitter is proportional to the distance of the object from the camera, and measure distance vis phase offset.

$$\varphi_{TOF} = \text{atan} \left( \frac{C_1 - C_3}{C_2 - C_4} \right)$$
$$D = \frac{c}{2} * \frac{\varphi_{TOF}}{2\pi * f_m} + D_{offset}$$

Formula 2-1. distance calculation

The phase offset ( $\varphi$ ) and depth ( $D$ ) are obtained by the integral energy values from the above formulas  $C_1$ ,  $C_2$ ,  $C_3$ , and  $C_4$ . These values are the energy collected

by four receiving windows with different phase delays, and corresponding to sampling at  $0^\circ$ ,  $90^\circ$ ,  $180^\circ$ , and  $270^\circ$  at the phase sampling points. As:

$$C_1 = A\sin(\varphi)$$

$$C_2 = A\sin(\varphi + 90^\circ) = A\cos(\varphi)$$

$$C_3 = A\sin(\varphi + 180^\circ) = -A\sin(\varphi)$$

$$C_4 = A\sin(\varphi + 270^\circ) = -A\cos(\varphi)$$

### Formula 2-2. Energy value and phase

A is the amplitude of the received sinusoidal signal

In terms of precision, the precision of CW-iToF is mainly subject to random noise and quantization noise. The former is inversely proportional to the signal-to-noise ratio (SNR) of the received optical signal, and the latter is inversely proportional to the sine wave modulation frequency. Therefore, in order to improve the precision, CW-iToF generally adopts high-power short integration time sampling to improve the SNR of the received optical signal; at the same time, the modulation frequency is increased to suppress quantization noise.

In terms of range, the phase range that can be resolved by CW-iToF is  $[0\sim 2\pi]$ , its maximum range is  $D_{max}=c/(2fm)$ . Therefore, the higher the frequency, the higher precision and the smaller range. If the depth of the range is exceeded, the periodic phase wrap (Phase wrap) measurement value will erroneously fall within  $[0\sim D_{max}]$ .

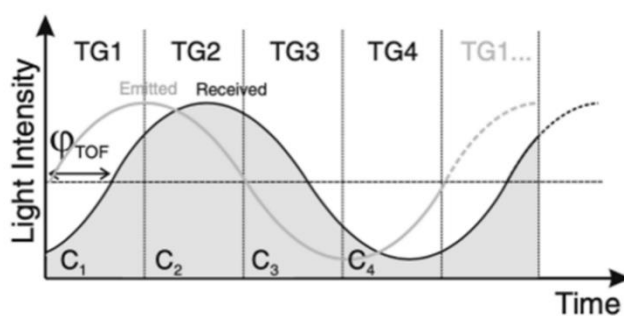

Figure 2-1. Light time of flight and light intensity

## 2.3 Camera System Frame Diagram

The CS30 RGBD depth camera hardware system includes 3 main components, the processor mainboard, the ToF module, and the RGB module. The ARM

processor is located on the mainboard, and the ToF and RGB modules are buckled on the mainboard through connectors.

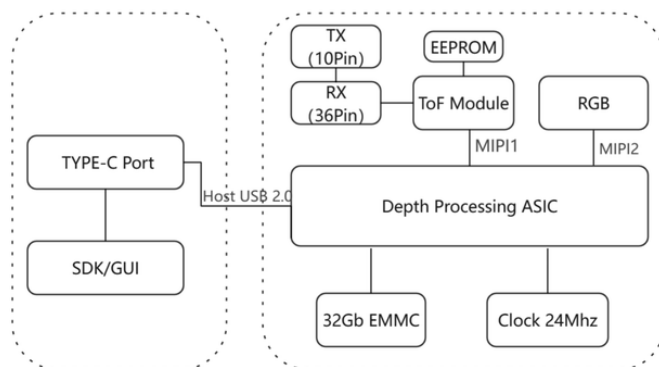

Figure 2-2. CS30 RGBD Camera System Frame Diagram

## 2.4 Technical parameter

Technical parameter		
depth image	Resolution	640*480/320*240
	FOV	H100°xV75°
color image	Resolution	1920*1080/640*480
	FOV	H97°xV59.5°
RGBD fusion	Resolution	1920 x 1080
	FOV	H91.5°xV59°
Basic parameters	Working distance	0.1-5m, indoor
	VCSEL wavelength	940nm
	precision	0.1~0.5m: ±2.5cm; 0.5~5m: ±1% @ 90% reflectivity
	Size	90mm x 25mm x 25mm
	data transmission	USB 2.0 , Type C Interface
	Power supply	5V, average 0.6A
	Power consumption	average 3W
	operating system	Win 10, Ubuntu, ROS
	Operating temperature	-10 ~ 50°C
	safety	Laser CLASS1

Frame rate and resolution		
Resolution	Filtering	No filtering
Depth(640*480)+RGB(960*540)	10fps	12~13fps
Depth(640*480)+RGB(1920*1080)	10fps	12~13fps
Depth(640*480)	9~10fps	15fps

## 3. Component Specifications

### 3.1 ToF module

Component	Description
ToF imager	Time of light image sensor
ToF emitter	Class 1 laser compliant (optional)
Other Components	Laser Driver, EEPROM, Voltage Regulators, FPC, Connector etc.

Table 3-1. ToF module components

#### 3.1.1 ToF Module Image Sensor

Component	Description
Active Pixels	640*480/320*240
Sensor Aspect Ration	4: 3
Format	10-bit RAW
Shutter Type	Global shutter
Signal Interface	MIPI CSI-2, 2X Lanes
F Number	1.2
Focal Length	2.534mm
Focus	Fixed
Horizontal Field of View	100.2
Vertical Field of View	75.1
Diagonal Field of View	125.5
TV Distortion	<11.8%

Table 3-2. ToF Image sensor parameters

#### 3.1.2 ToF Module Laser Emitter

The ToF laser emitter emits uniform near-infrared (940nm) light to the object, and the laser emitter meets Class 1 laser safety requirements under normal operation.

Items	Test Condition	Min	Typical	Max	Unit
-------	----------------	-----	---------	-----	------



Optical Output power	Pulse=5.0A, 50°C	-	4.3	-	W
Threshold current	Pulse 50°C	-	-	1	A
Operating Current	Pulse 50°C	-	5	-	A
Operating voltage	Pulse=5.0A, 50°C	-	2.0	-	V
Slope efficient	Pulse=5.0A, 50°C	-	1	-	mW/mA
Power conversion efficiency	Pulse=5.0A, 50°C	-	43	-	%
Angle	Pulse=5.0A, 50°C	-	110.25	-	°
	Pulse=5.0A, 50°C	-	90.22	-	
Wavelength	If=5.0A, 50°C	938	940	942	nm
Wavelength coefficient	Pulse=5.0A	-	0.07	-	nm/°C

Table 3-3. ToF Module Laser Emitter Parameters

### 3.2 RGB Module

In addition to color images, the color sensor on the stereo depth module also provides texture information. Uses for texture information include overlaying depth images to create colored point clouds, and overlaying 3D models for reconstruction.

Component	Description
Active Pixels	1920*1080/640*480
Sensor Aspect Ration	16: 9
Format	10-bit RAW
Shutter Type	Rolling shutter
Signal Interface	MIPI CSI-2, 2X Lanes
F Number	2.5
Focal Length	2.3mm
Focus	Fixed
Horizontal Field of View	112
Vertical Field of View	63
Diagonal Field of View	136
TV Distortion	-28%

Table 3-4. RGB Module parameters

### 3.3 Processor Mainboard

Components	Description
Vision Processor	Depth Processing ASIC
32Gb EMMC	Vision Processor firmware storage and RGB firmware storage
24 MHz Crystal	Clock source for Vision Processor
Depth Module Receptacle	(36+10)pin receptacle for connection to Depth Module
RGB Module Receptacle	20pin receptacle for connection to RGB Module
USB Type-C	USB peripheral connector for connection to Host USB 2.0 port
Voltage Regulators	DC to DC and LDO converters powering Vision Processor Board and depth module
Mounting holes	Vision Processor Board secure mounting

Table 3-5.Processor Mainboard Components

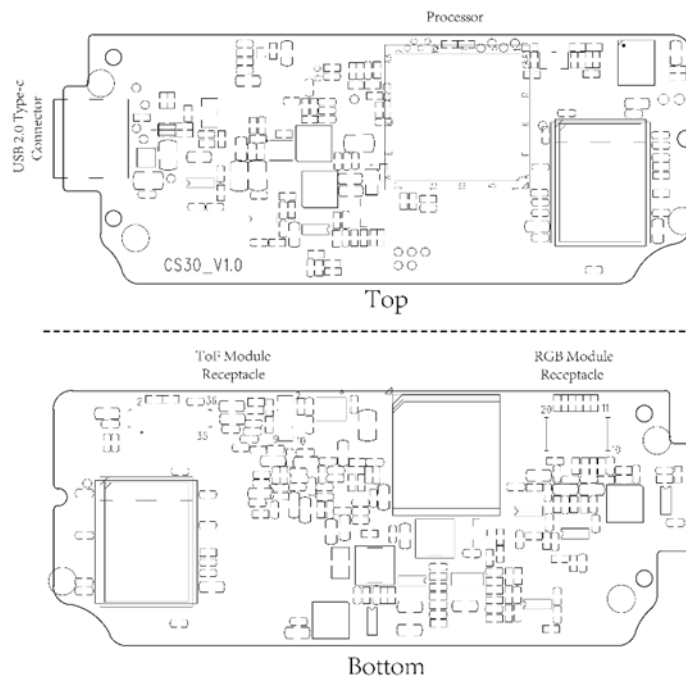

Figure 3-1. CS30 Processor mainboard Schematic diagram

Dimension	Min	Nominal	Max	Unit
Length	70.5	70.6	70.7	mm
Width	27.6	27.7	27.8	mm
Height	5.5	5.7	5.9	mm
Weight	9.6	10	10.3	g

Table 3-6. Processor mainboard size

### 3.3.1 Type C Description

A1	A4	A5	A6	A7	A8	A9	A12
GND	VBUS	CC1	DP1	DN1	SBU1	VBUS	GND
GND	VBUS	SBU2	DN2	DP2	CC2	VBUS	GND
B12	B9	B8	B7	B6	B5	B4	B1

Figure 3-2. USB Type-C Receptacle Pin Map

Pin	Signal	Function	Pin	Signal	Function
A1	GND	接地	B12	GND	接地
A4	VBUS	总线电源	B9	VBUS	总线电源
A5	CC1	Configuration channel	B8	SBU2	NC
A6	DP1	USB 2.0差分信号, position 1, 正	B7	DN2	USB 2.0差分信号, position 2, 负
A7	DN1	USB 2.0差分信号, position 1, 负	B6	DP2	USB 2.0差分信号, position 2, 正
A8	SBU1	NC	B5	CC2	Configuration channel
A9	VBUS	总线电源	B4	VBUS	总线电源
A12	GND	接地	B1	GND	接地

Figure 3-3. USB Peripheral Connector Pin List

### 3.4 Power consumption

Condition	Imin (mA)	Iavg (mA)	Ipp (mA)
Standby(whole machine)	80	82.6	85
Mainboard	58	82.6	200
Mainboard+ToF Module	197	220	527
Mainboard+RGB Module	63	140.1	201
Mainboard+ToF Module+RGB Module	201	286	609
Supply voltage: VBUS=5V, Measured data based on exposure time=3000us.			

Table 3-7. CS30 RGBD Depth camera power consumption indicators

## 4. Performance evaluation

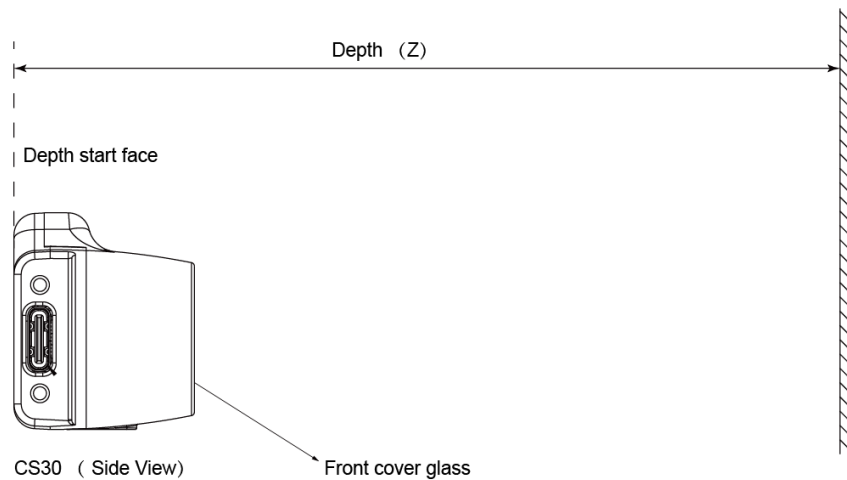

Figure 4-1 CS30 Evaluation starting point

- 1) Absolute accuracy: refers to the difference between the measurement result and the real data, it is used to characterize the closeness of the measurement result to the real data, The formula is defined as follows

$$Accuracy = \left| \frac{\sum_i depth_i}{N} - D \right|$$

- 2) Inter-frame noise: It is used to evaluate the stability of depth data between multiple frames. The formula of inter-frame noise is defined as follows:

$$Temporal\ noise = \frac{1}{N} \sum_i \sqrt{\frac{\sum_j \left( depth_j - \frac{\sum_j depth_j}{M} \right)^2}{M}}$$

3) Point cloud thickness: shoot the white wall and test the point cloud thickness of the white wall at different distances.

## 5. Mechanical structure

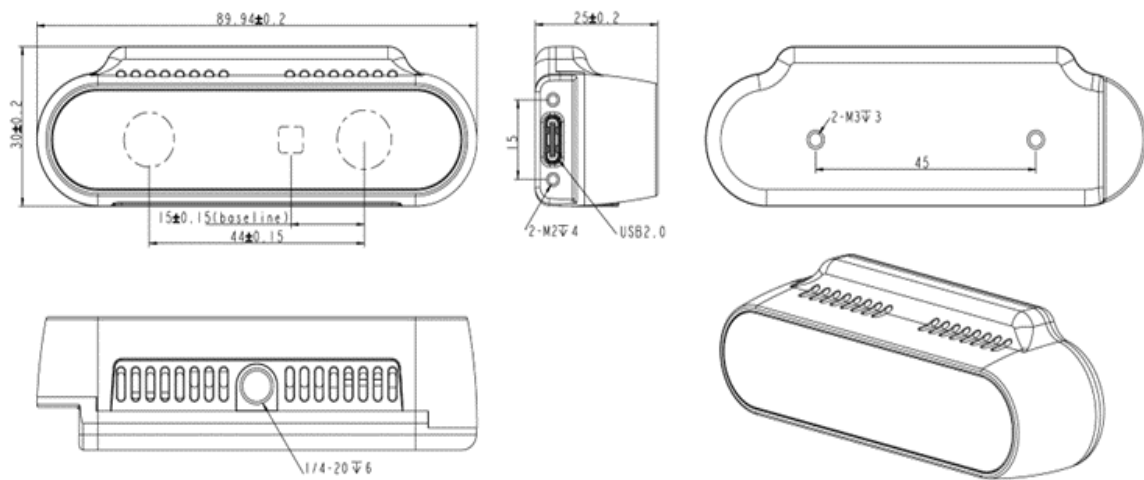

Figure 5-1 CS30 RGBD Depth camera structure Schematic diagram

Dimension	Min	Nominal	Max	Unit
Length	89.74	89.94	90.14	mm
Width	29.8	30	30.2	mm
Height	24.8	25	25.2	mm
Weight	73.5	74	74.5	g

Table 5-1. Structure size

## 6. Storage conditions

Condition	Description	Min	Max	Unit
Storage Temperature		-15	60	°C
	Humidity	Temperature/RH: 40°C/90%		
Work Temperature		-10	50	°C

## 7. Camera Cleaning Steps

1. Do not spill any chemicals or water on the camera lens
2. Remove dust and dirt from the lens with a lens blower
3. Wipe with a dry, clean microfiber cloth

## 8. Software

- [Windows ---Credimension Viewer](#)

Credimension Viewer is CS30 series windows demo GUI Tool. This tool is mainly used to obtain display and save Depth, IR, Point cloud, RGB information, at the same time, it supports functions such as viewing the basic information of the device and setting the resolution and integration time.

- [SDK---Libsynexens](#)

Customers can use CS30 SDK for secondary development, which supports Windows/Linux platforms and x86\_64 and ARMv7/ARMv8 architectures, and has made specific performance optimizations for embedded architectures. Please refer to the supporting documentation in the SDK for more detailed information.

## 9. Compliance regulations

“ ROHS、 CLASS 1 ”

### Disclaimer

The device application information and other similar content described in this publication is provided for your convenience only and may be superseded by updated information. It is your responsibility to ensure the application meets the technical specifications. Regarding this information, our company does not make any express or implied, written or oral, statutory or other statements or guarantee, including, but not limited to, representations or warranties with respect to its use, quality, performance, merchantability or fitness for a particular purpose. Our company does not assume any responsibility for this information and the consequences arising from its use. This product must not be used as a critical component in life support systems without the written approval of the company.